

FIVE NEW SPECIES OF ARGYROTAENIA (TORTRICIDAE: ARCHIPINI) FROM MEXICO AND THE SOUTHWESTERN UNITED STATES

JOHN W. BROWN

Systematic Entomology Laboratory, Plant Sciences Institute, Agricultural Research Service, U.S. Department of Agriculture
c/o National Museum of Natural History, Washington, DC 20560-0168, U.S.A. (e-mail: jbrown@sel.barc.usda.gov)

AND

ASHLEY CRAMER

Department of Biology, University of New Mexico, Albuquerque, New Mexico 87131, U.S.A.

ABSTRACT. Based on an examination of 187 specimens, five new species of *Argyrotaenia* are recognized from Mexico and the southwestern United States. A hypothesis of the phylogenetic relationships among the species is derived using Hennig86 to find the most parsimonious solution to the distribution of 14 morphological characters (5 characters of the forewing, 7 of the male genitalia, and 2 of the female genitalia). *Argyrotaenia spinacallis* Brown & Cramer, new species, from the State of Veracruz, *A. unda* Brown & Cramer, new species, from the states of Mexico and Morelos, and *A. octavana* Brown & Cramer, from the states of Puebla and Veracruz, appear to form a monophyletic group with *A. ponera* (Walsingham), from Puebla. The last is redescribed and illustrated. Although superficially similar, *A. coconinana* Brown & Cramer, new species, from Arizona and New Mexico, and *A. bialbistriata* Brown & Cramer, from Arizona (Cochise Co.) and Durango, Mexico, may not be members of the “*ponera* group” owing to their considerable divergence in male and female genitalia.

Additional key words: phylogeny, *ponera* group, morphology, genitalia.

With the exception of a single widespread Palearctic species, the tortricid genus *Argyrotaenia* Stephens is restricted to the New World (Razowski 1997), with about 64 described species occupying portions of the Western Hemisphere from Canada to Argentina. Field work over the past four decades has revealed a surprisingly large number of undescribed species in Central and South America. The purpose of this paper is to describe three of them from central Mexico that appear to form a monophyletic group with *Argyrotaenia ponera* (Walsingham), and two from the southwestern United States and northern Mexico that are superficially similar to *A. ponera*. Although the “*ponera* group” may be confined to Mexico, it is clearly temperate/boreal rather than tropical in origin, restricted to the higher elevations of the Mexican states of Mexico, Morelos, Puebla, and Veracruz. The five new species described herein underscore the considerable alpha-level taxonomic work that remains to be done in the New World south of the United States border.

MATERIALS AND METHODS

Material examined. We examined 187 pinned specimens of adult moths obtained from or studied at the following institutions: American Museum of Natural History (AMNH), New York, New York; The Natural History Museum (BMNH), London, United Kingdom; Canadian National Collection (CNC), Ottawa, Ontario, Canada; Ray B. Nagle private collection (RNC), Tucson, Arizona; Essig Museum of Entomology (UCB), University of California, Berkeley; and National Museum of Natural History (USNM), Smith-

sonian Institution, Washington, DC. Specimens were sorted by geographic location and examined for differences in the male and female genitalia. Genitalia preparations of representative individuals were made following the methodology summarized in Brown and Powell (1991). Male genitalia were photographed using a SONY DKC5000 digital camera and enhanced using Adobe Photoshop. Illustrations of female genitalia were drawn with the aid of a microprojector. Unless indicated otherwise, genitalia illustrations are of a single preparation. Forewing measurements were made with a transparent millimeter ruler under low power of a Leica MZ12 dissecting microscope. Forewing length was measured in a straight line from the base of the wing to the apical region, including the fringe. Forewing width was measured at the widest place on the wing perpendicular to the line measuring length. Where available, 10 individuals of each sex were measured. Photographs were taken with a Wild M 400 microscope with camera attachment. Terminology for wing venation and genitalic structures follows Horak (1984). Abbreviations are as follows: FW = forewing; HW = hindwing; DC = discal cell; ca. = circa (approximately); n = number of individuals or preparations examined; \bar{x} = mean; Mtns = Mountains; N, S, E, W = compass points.

Phylogeny. A phylogenetic analysis was conducted on the 6 species of *Argyrotaenia* suspected to comprise the “*ponera* group” (plus an out-group). The analysis was based on 14 morphological characters (8 binary and 6 multi-state), including 5 characters of the forewing, 7 of the male genitalia, and 2 of the female

TABLE 1. Morphologic characters for cladistic analysis (0 = plesiomorphic state; 1–3 = apomorphic states).

1. FW L:W ratio	0 - 2.3–2.7 1 - 2.8–3.0
2. FW length	0 - 9.0–10.5 mm 1 - 11.0–13.0 mm.
3. FW pattern elements	0 - Without white spot at end of DC 1 - With diffuse white spot at end of DC
4. FW pattern elements	0 - Without pale longitudinal streak 1 - Pale longitudinal streak weak, extending to ca. end of DC 2 - Pale longitudinal streak well-developed, extending beyond end of DC
5. FW pattern elements	0 - Without dark longitudinal streak below distal two-thirds of DC 1 - With dark longitudinal streak below distal two-thirds of DC
6. Shape of valva	0 - Somewhat rounded-triangular 1 - Subrectangular
7. Base of sacculus	0 - Unmodified 1 - With small rounded lobe 2 - With moderate, partially free, rounded lobe 3 - With large, free, rounded lobe
8. Venter of sacculus	0 - Smooth 1 - Slightly bumpy/warty 2 - With spinelike teeth
9. Uncus	0 - Unmodified, moderately broad 1 - Extremely broad
10. Uncus	0 - Unmodified, uniform in width 1 - Slightly tapered distally
11. Aedeagus	0 - Smooth 1 - With 2–4 spinelike teeth at distal end 2 - With 4–6 spinelike near middle 3 - With irregular rows of spinelike teeth from middle to end
12. Aedeagus	0 - About 4 times as long as wide, weakly curved 1 - Greater than 6 times as long as wide, strongly curved
13. Antrum	0 - Small, poorly defined 1 - Well developed, funnel shaped 2 - Large, cup shaped
14. Signum	0 - Lacking sclerotized projections from region bearing capitulum 1 - With sclerotized projection extending anterad from area bearing capitulum. 2 - With sclerotized projection extending posterad from area bearing capitulum.

genitalia. Character state polarity was determined primarily using the out-group method. Although sister-group relationships are virtually unknown for *Argyrotaenia*, recent work by Landry et al. (1999) has identified a monophyletic species group comprised of *A. franciscana* (Walsingham), *A. citrana* (Fernald), *A. citrana isolatissima* Powell, *A. citrana insularis* Powell, *A. niscana* (Kearfott), and an undescribed species; this group was used as the out-group.

Descriptions of character states. The character states used in the analysis are described below. Their putative plesiomorphic and apomorphic states are presented in Table 1, and their distribution among the taxa is presented in Table 2.

Forewing (Characters 1–5). Most species of *Argyrotaenia*, including the out-group, have a rather broad forewing with a pattern that typically includes one or more oblique fascia and a small, flattened, triangular patch at the costa about two-thirds the distance from the base to the apex. All of the species in the putative “*ponera* group” have a more narrow forewing that lacks the typical *Argyrotaenia* pattern. A forewing

length-to-width ratio of 2.3–2.7, present in the out-group, was considered the plesiomorphic condition (character state 1.0); a forewing length-to-width ratio of 2.8–3.0 was considered the apomorphic condition (character state 1.1). A comparatively small forewing length (9.0–10.5 mm) was assumed to represent the plesiomorphic condition (character state 2.0), and a larger forewing length (11.0–13.0 mm) the apomorphic state (character state 2.1). A forewing without a white spot at the distal end of discal cell was assumed to represent the primitive condition (character state

TABLE 2. Distribution of character states for cladistic analysis (“?” = missing data).

outgroup	000 000 000 000 00
<i>ponera</i>	111 200 310 021 ??
<i>spinacallis</i>	101 000 210 131 11
<i>unda</i>	101 100 110 111 21
<i>octavana</i>	101 100 110 111 20
<i>coconinana</i>	110 211 121 000 02
<i>bialbistriata</i>	100 211 121 000 01

3.0), and a forewing with a diffuse white spot at the end of the discal cell, characteristic of *A. ponera*, *A. spinacallis*, *A. unda*, and *A. octavana*, the apomorphic state (character state 3.1). The absence of a pale longitudinal streak through the discal cell of the forewing was interpreted as plesiomorphic (character state 4.0); the presence of an ill-defined or narrow, pale longitudinal streak extending from the forewing base to about the end of the discal cell, as is present in *A. unda* and *A. octavana*, was interpreted as derived (character state 4.1); and the presence of a well-developed pale longitudinal streak extending from near the base of the forewing to beyond the end of the discal cell, present in *A. ponera*, *A. coconinana*, and *A. bialbistriata*, was considered the most derived state (character state 4.2). The absence of a dark longitudinal streak below the distal two-thirds of the discal cell of the forewing was considered the plesiomorphic condition (character state 5.0), and the presence of a dark longitudinal streak in this region was considered the apomorphic condition (character state 5.1).

Male genitalia (Characters 6–12). A short, somewhat rounded-triangular valva, present in many species of *Argyrotaenia* including the out-group, was considered plesiomorphic (character state 6.0), and a subrectangular valva apomorphic (character state 6.1). An unmodified base of the sacculus was considered plesiomorphic (character state 7.0); the presence of a small, rounded lobe the first step in the transformation series (character state 7.1); the presence of a well-developed, partially free, rounded lobe the next advancement (character state 7.2); and the presence of a large, free, rounded lobe the final step in the series (character state 7.3). The venter of the sacculus is relatively smooth in most species of *Argyrotaenia* (character state 8.0). A slightly bumpy or warty ventral margin was considered derived (character state 8.1), and the presence of spinelike teeth along the margin, characteristic of *A. coconinana* and *A. bialbistriata*, was considered the most derived state (character state 8.2). A moderately broad uncus (character state 9.0) of uniform width (character state 10.0) is present in most species of *Argyrotaenia*. The extremely broad uncus of *A. coconinana* and *A. bialbistriata* was considered the apomorphic condition (character state 9.1). An uncus that is slightly tapered distally also was considered an apomorphic state (character state 10.1). The moderately slender, slight curved aedeagus lacking external spines, present in *A. coconinana* and *A. bialbistriata*, was considered the plesiomorphic state (character state 11.0). An aedeagus with 2–4 spinelike teeth at the distal end (character state 11.1) was considered the first step in a transformation series leading to 4–6

spinelike teeth near the middle of the aedeagus (character state 11.2) and irregular rows of spinelike teeth from near the middle to the distal tip of the aedeagus (character state 11.3). A comparatively short (about 4 times as long as wide), weakly curved aedeagus, present in *A. coconinana* and *A. bialbistriata*, was considered the plesiomorphic state (character 12.0), and a relatively long (greater than 6 times as long as wide), slender, strongly curved aedeagus (character state 12.1), present in *A. ponera*, *A. spinacallis*, *A. unda*, and *A. octavana*, was considered the apomorphic state.

Female genitalia (Characters 13–14). A small, poorly defined antrum was considered plesiomorphic (character state 13.0); a well developed, funnel-shaped antrum apomorphic (character state 13.1); and a large, cup-shaped antrum the most derived state in the transformation series (character state 13.2). In most *Argyrotaenia* the signum is typical of other members of the tribe Archipini, with a well developed, elongate, interior spine and an external capitulum (see Horak 1984). Because of the extremely variable configuration and development of internal sclerites extending dorsad and posterad from the area bearing the capitulum, we selected the most simple condition, i.e., sclerites absent, as the plesiomorphic state (character state 14.0). The presence a sclerotized projection extending anterad of the capitulum (character 14.1) was interpreted as apomorphic, and the presence of an additional sclerotized projection extending posterad (character state 14.2) was considered the most derived state.

RESULTS

The data set was subjected to parsimony analysis using Hennig86 version 1.5 (Lipscomb 1994), employing the "mhennig*" command. This algorithm constructs trees, each by a single pass through the data, by adding the taxa in a different sequence each time, and then applies branch-swapping to each of the trees. The analysis generated one most parsimonious tree with a length of 27, a consistency index of 0.81, and a retention index of 0.77. The resulting cladogram (Fig. 1) indicates that *A. unda*, *A. ponera*, *A. spinacallis*, and *A. octavana* form a monophyletic group supported by the following characters: 1) diffuse white spot near end of the discal cell of the forewing (character 3); 2) rounded lobe at the base of the sacculus (character 7); 3) spinelike teeth on the aedeagus (character 11); 4) a long, slender, curved aedeagus (character 12); and 5) antrum well developed (character 13). The basal position of *A. coconinana* plus *A. bialbistriata*, with a comparable set of characters supporting their monophyly, suggests that they may not be members of the "ponera group" as currently defined. The cladogram (Fig. 1) is

concordant with the geographic distribution of the species (Fig. 2), i.e., *A. unda*, *A. spinacallis*, *A. octavana*, and *A. ponera* occur in close geographic proximity, while *A. coconinana* and *A. bialbistriata* occur relatively far to the north.

All of the species treated herein are distinguished from other *Argyrotaenia* by the absence of the typical semicircular or triangular subapical patch of dark scales on the forewing characteristic of most species, and the presence of a diffuse white dot near the termination of the discal cell or a pale streak through the discal cell. The forewing is more elongate or narrow than most species in the genus: forewing length: width ranges from 2.8–3.0 (\bar{x} = 2.9; n = 10) for the included species in contrast to 2.3–2.8 (\bar{x} = 2.6; n = 10) for members of the *franciscana* group. According to Powell (pers. comm.), the latter feature is characteristic of cold temperature microlepidoptera in various families (e.g., Elachistidae (Ethmiinae), Tortricidae). The short, somewhat rounded-triangular valvae and broad uncus of the species treated herein are similar to many other congeners, e.g., *A. franciscana* and *A. amatana* (Dyar), and the large, cup-shaped antrum of *A. unda*, new species, is highly reminiscent of that of *A. dichotoma* (Walsingham), of which no males are known.

The dichotomous key below is based on maculation and size of forewing. However, genitalia are much more reliable than facies for species-level identifications, and dissections are recommended. Although males of each species possess at least one diagnostic feature, shapes of the antrum and the signum in the female exhibit considerably more conspicuous and reliable differences.

KEY TO THE SPECIES OF THE *PONERA* GROUP

- 1. Forewing with at least one white or pale yellow longitudinal streak extending through discal cell 2
- 1'. Forewing without pale longitudinal streak in discal cell (Fig. 4) *spinacallis*
- 2. Pale longitudinal streak extending along upper portion of discal cell arising at or near base of forewing 4
- 2'. Pale longitudinal streak extending along upper portion of discal cell arising approximately one-fourth distance from base to apex of forewing, bordered below in distal two-thirds by a distinct, narrow, dark brown streak 3
- 3. Female with second white streak along lower edge of discal cell; male forewing ground color usually red brown; Durango, Mexico, southeastern Arizona (Fig. 8) *bialbistriata*
- 3'. Female without second white streak along lower edge of discal cell; male forewing ground color usually pale brown; Arizona, New Mexico (Fig. 7) *coconinana*
- 4. Forewing length greater than 11.0 mm (Fig. 3) *ponera*
- 4'. Forewing length less than 11.0 mm 5
- 5. Forewing with distinct rust-brown dash along costal edge of discal cell in distal one-third; diffuse whitish spot at end of cell (Fig. 5) *unda*
- 5'. Forewing lacking distinct rust-brown dash along costal edge of discal cell; fine white dot at end of cell (Fig. 6) *octavana*

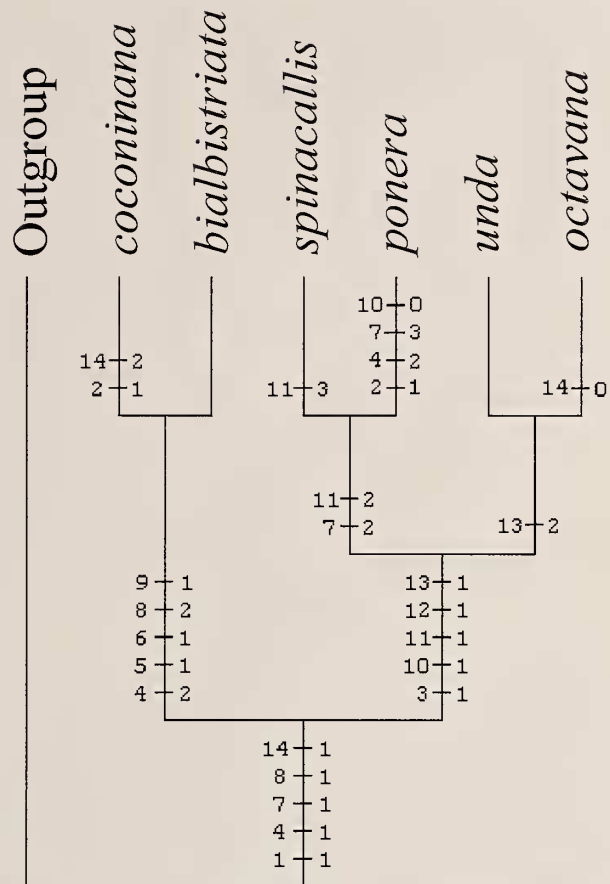

FIG. 1. Hypothesis of phylogenetic relationships among *Argyrotaenia ponera*, *A. spinacallis*, *A. unda*, *A. octavana*, *A. bialbistriata*, and *A. coconinana*. Numbers on the left refer to characters (1–14); numbers on the right refer to character states (e.g., 0 = plesiomorphic, 1–3 = apomorphic) (see Tables 1 and 2).

SYSTEMATICS

Argyrotaenia ponera (Walsingham)
(Figs. 3, 9)

Tortrix ponera Walsingham, 1914:279.

Argyrotaenia ponera: Obraztsov 1961:38; Powell et al. 1995:147.

Redescription. Male. Head: Frons with sparse, smooth scaling below mid eye, pale red brown; vertex roughened above, light brownish red. Labial palpus pale red brown mesally, light brownish red laterally. Antennal scaling brown; scape pale red brown, frosted with whitish scales. Thorax: Light brownish copper, lighter mediodorsally. Forewing (Fig. 3): Length 11.0–13.0 mm (\bar{x} = 12.2; n = 10). Upper side light brown; a conspicuous silver-white longitudinal streak extending from base, ending in a distinct silver-white dot just beyond end of DC, more diffuse and ill-defined from spot to termen; an ill-defined, darker brownish copper longitudinal streak immediately above white longitudinal streak; a small patch of darker brownish copper scales below silver-white streak beyond end of DC, accentuating silver-white dot near end of DC. Fringe pale gray. Under side pale gray. Hindwing: Upper side pale gray. Fringe slightly lighter than ground color. Under side pale gray. Genitalia: As in Fig. 9 (photograph of JWB slide 1035, Puebla, Mexico; 3 preparations examined). Uncus moderately broad, uniform in width, with truncate tip. Socius short, fused with tegumen. Arms of gnathos narrow,

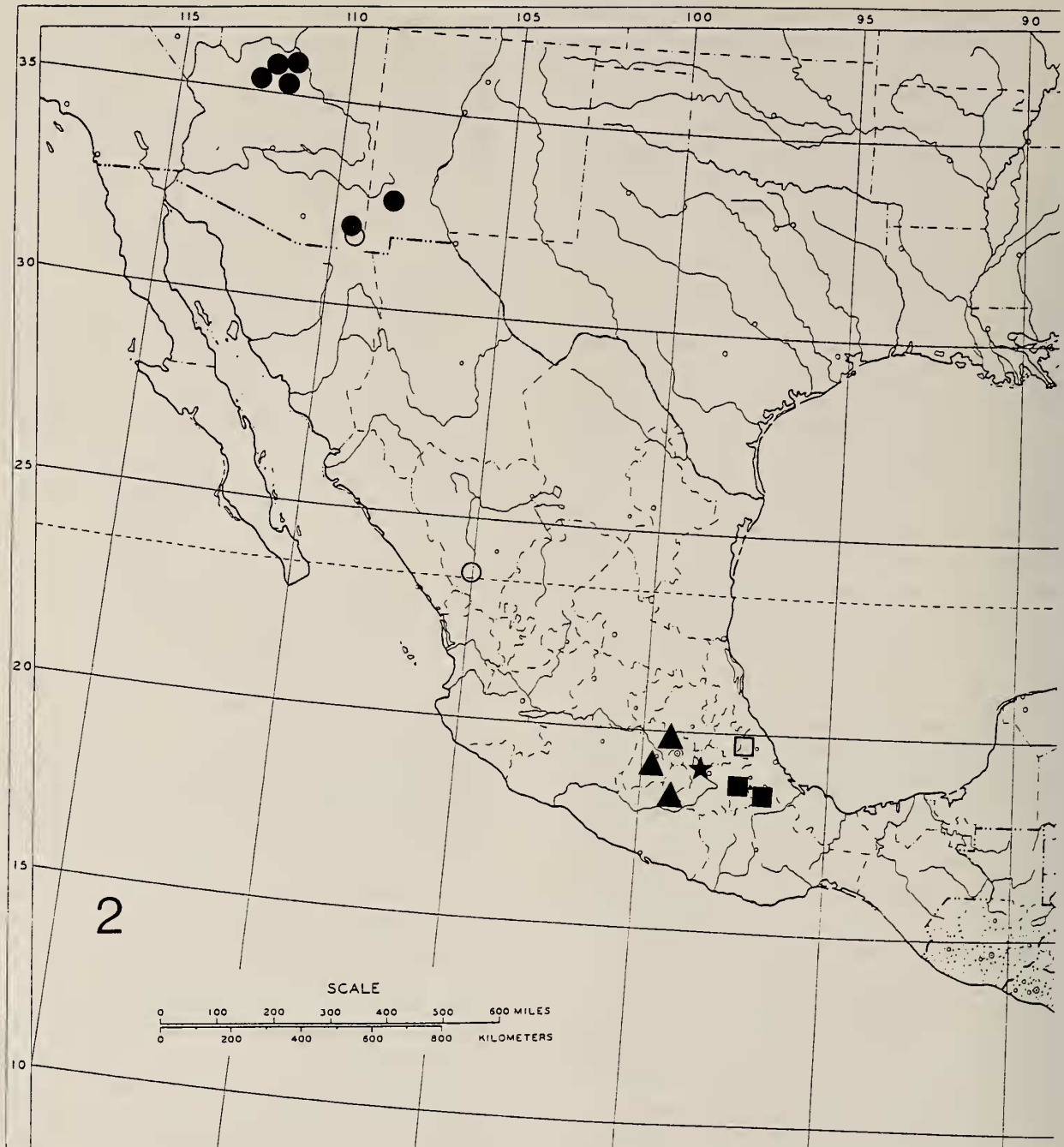

FIG. 2. Geographic distribution of *Argyrotaenia ponera* (star), *A. spinacallis* (open square), *A. unda* (closed triangles), *A. octavana* (closed squares), *A. bialbistriata* (open circles), and *A. coconinana* (closed circles).

uniform in width, united distally into an elongate pointed tip. Transtilla a simple, sclerotized, narrow band. Valva short, somewhat rounded-triangular, costa undifferentiated; sacculus moderately long, slender, curved, ending ca. 0.8 distance from base to apex; base of sacculus with large, free, semicircular lobe; venter of distal 0.5 of sacculus with small bumps. Aedeagus long, slender, curved, with 4-6 spine-like teeth near the middle along right side; cornuti not evident

(deciduous and lost); phallobase moderate, slightly swollen distad to attachment point of juxta.

Female. Unknown.

Holotype ♂, Mexico [Puebla], Popocatepetl Park, 13,000' [4000 m], 6047 Wlsm 1908 (Wm. Schaus, USNM).

Paratypes. Same data as holotype, 1 ♂, "co-type," 33946 (BMNH), 1 ♂, "co-type," 33947 (BMNH).

Additional specimens examined. MEXICO: Puebla: Popocatepetl Park, 13,000' [4000 m], 1 ♂ (USNM), 1 ♂, "co-type" Wlsm 6048 (USNM); Tlmacas, Volcan Popocatepetl, 3600–3660 m, 7 ♂, 24 August 1987 (J. Brown & J. Powell, UCB).

Diagnosis. *Argyrotaenia ponera* is superficially most similar to *A. coconinana*, from which it can be distinguished by the following features: 1) ground color of the forewing brownish copper rather than pale brown, lacking a distinct dark brown streak below silver-white streak; 2) large, well-defined lobe at the base of the sacculus, less defined in *A. coconinana*; 3) ventral edge of the distal 0.5 of the sacculus bumpy rather than dentate; and 4) aedeagus longer and more evenly curved, with 4–6 spinelike teeth near the middle.

Remarks. Walsingham (1914:279) had 4 specimens when he described *Tortrix ponera*: one was designated as the holotype ["HT"] (USNM) and two as paratypes ["PT"] (BMNH), although the latter two are labeled as "co-types." The fourth specimen (6048 Wlsm) also is labeled "co-type" but was not designated as a paratype in the original description—it is referred to only after the locality data: "Four specimens." There is one additional specimen (USNM) with identical collecting data that was not mentioned (or seen?) by Walsingham. Obraztsov's (1961:35) illustration of *A. ponera* includes a photograph of an aedeagus, which is not that of the holotype of *A. ponera*.

Argyrotaenia spinacallis Brown & Cramer, new species

(Figs. 4, 11, 15)

Description. Male. Head: Frons with sparse, smooth scaling below mid eye, pale red brown; vertex roughened above, pale red brown. Labial palpus pale yellow mesally, pale red brown laterally. Antennal scaling light brown; scape brown, with pale red-brown scales. Thorax: Light brown. Forewing (Fig. 4): Length 9.5–10.5 mm (\bar{x} = 10.0; n = 10). Upper side with costal one-half mostly copper brown, lower one-half pale yellow orange; distal one-third faintly reticulated; occasionally with ill-defined, thin, pale red-brown longitudinal streak along lower edge of DC; a pair of diffuse, small, dark-brown spots near distal end of DC, separated by diffuse white streak. Fringe pale red brown with basal row of slightly darker red-brown scales. Under side pale gray. Hindwing: Upper side pale gray. Fringe concolorous with hindwing. Under side pale gray. Genitalia: As in Fig. 11 (photograph of JWB slide 1063, Veracruz, Mexico; 3 preparations examined). Uncus moderately broad, with truncate tip. Socius short, fused to tegumen. Gnathos united distally into moderately long, pointed tip. Transtilla a simple, sclerotized, narrow band. Valva short, somewhat rounded-triangular, costa undifferentiated; sacculus moderately long, curved, attenuate distally, ending in a short free tip ca. 0.85 distance from base to apex; sacculus with moderately large, rounded, partially free lobe at base; venter of sacculus weakly dentate in distal 0.25. Aedeagus moderately long, slender, curved near middle; irregular rows of spinelike teeth from near middle to distal end of aedeagus. Cornuti not evident (deciduous and lost).

Female. FW length 9.3–9.5 mm (\bar{x} = 9.4; n = 2). Essentially as described for male, except hindwing with pale gray-brown overscaling. Genitalia: As in Fig. 15 (drawn from JWB slide 1036, Veracruz, Mexico; 2 preparations examined). Papillae anales unmodified, broad. Sterigma a slender, strongly sclerotized, weakly undulate band; ostium bursae moderately broad; antrum large, funnel shaped, with long ventral tube, strongly sclerotized. Ductus bursae moderately long, with distinct junction between corpus bursae and ductus bursae. Corpus bursae ovoid; signum with sclerite extending posterad of capitulum greatly reduced, portion extending anterad well developed.

Holotype ♂, Mexico, Veracruz, Cañon de las Minas, 13 km NE Perote, 2150 m, 18 August 1987 (J. Brown & J. Powell, UCB).

Paratypes. Same data as for holotype, 20 ♂, 2 ♀, 18/19 August 1987 (J. Brown & J. Powell, UCB), 1 ♂, 19 August 1987 (J. Doyen, UCB).

Additional specimen examined. MEXICO: Mexico: La Marquesa, 1 ♂, 13 July 1966 (O. Flint & A. Ortiz, USNM).

Diagnosis. *Argyrotaenia spinacallis* differs from all other species in the group by the absence of the pale longitudinal streak

on the forewing. Average male forewing length (10.0 mm) is less than that of *A. ponera* (12.2 mm) and *A. coconinana* (12.2 mm) and slightly greater than that of *A. unda* (9.4 mm) and *A. octavana* (9.4 mm). The female genitalia of *A. spinacallis* are distinguished easily from all other species by the strongly sclerotized, funnel-shaped antrum. In comparison with *A. ponera*, the male genitalia have slightly shorter, more rounded valvae; a slightly less well-developed rounded lobe at the base of the sacculus; and a slightly longer aedeagus, with irregular rows of spinelike teeth from near the middle to the distal end. The somber forewing pattern, spinelike teeth of the aedeagus in the male, and funnel-shaped antrum in the female easily separate this species from other members of the *ponera* group.

Remarks. The single male from La Marquesa is similar to *A. spinacallis* in general appearance, but has a larger forewing length (10.8 mm) and a darker brown ground color. Because the genitalia slide (Razowski no. 11072) apparently is lost, comparison of these structures is impossible; hence the specimen is not included in the type series. In addition to the locality and slide labels, the specimens bears a label indicating "Holotype" and one indicating "*Argyrotaenia ?ponera* Wlsm.," probably referring to *A. ponera*.

Etymology. The species name refers to the irregular rows of spinelike teeth on the aedeagus.

Argyrotaenia unda Brown & Cramer, new species

(Figs. 5, 10, 16)

Description. Male. Head: Frons with sparse, smooth scaling below mid eye, copper brown; vertex roughened above, yellowish white. Labial palpus pale red brown mesally, light copper laterally. Antennal scaling pale red brown; scape copper orange, with pale red-brown frosting. Thorax: Copper orange. Forewing (Fig. 5): Length 9.0–10.0 mm (\bar{x} = 9.4; n = 10). Upper side rust to light copper, rust brown apically; conspicuous thin, silver-white longitudinal streak from base to beyond middle of DC; an ill-defined pale-brown line immediately below silver-white streak; conspicuous rust brown streak along distal one-third of costal edge of DC, bordered above by diffuse white scaling, terminating in a diffuse silver-white spot. Fringe pale red brown. Under side light gold. Hindwing: Upper side white. Fringe yellowish white. Under side yellowish white. Genitalia: As in Fig. 10 (photograph of JAP slide 6271, Mexico, Mexico; 3 preparations examined). Uncus moderately broad, slightly tapered distally, with truncate tip. Socius, gnathos, and transtilla as in *ponera* and *spinacallis*. Valva short, costa slightly arched dorsally, with a lightly sclerotized subrectangular lobe near base; sacculus moderately long, curved, attenuate distally, ending in a short free pointed tip; base of sacculus with an ill-defined, semicircular lobe. Aedeagus moderately long, not as strongly bent as in *ponera* and *spinacallis*; distal end with 2–4 small spinelike teeth; cornuti 12–15 in a dense fascicle.

Female. FW length 9.0–10.0 mm (\bar{x} = 9.4; n = 6). Essentially as described for male, except hindwing with gray-brown overscaling. Genitalia: As in Fig. 16 (drawn from JAP 6272 slide, Mexico, Mexico; 3 preparations examined). Papillae anales unmodified, broad. Sterigma moderately heavily sclerotized; ostium bursae moderately small, somewhat crescent shaped; antrum extremely large, cup shaped, strongly sclerotized. Ductus bursae moderately long, with distinct junction between corpus bursae and ductus bursae; posterior one-third of ductus bursae broad, strongly sclerotized. Corpus bursae ovoid; signum with sclerite extending posterad of capitulum reduced; anteriorly-directed sclerite extremely elongate, attenuate, extending nearly to anteriormost wall of corpus bursae as narrow line.

Holotype ♂, Mexico, Mexico, 7 air km WSW Juchitepec, 2750 m, 24 August 1987 (J. Brown & J. Powell, UCB).

Paratypes. MEXICO: Mexico: same data as for holotype, 10 ♂, 3 ♀, 24/25 August 1987 (J. Brown & J. Powell, UCB); 10 air km SE Amecameca, 2720 m, 1 ♂, 23 August 1987 (J. Brown & J. Powell, UCB). Morelos: Lag. Zempoala, 3 ♀, 10/11 July 1965 (O. Flint & A. Ortiz, USNM).

Diagnosis. *Argyrotaenia unda* is superficially and genitally most similar to *A. octavana*. In facies most specimens of *A. unda* can

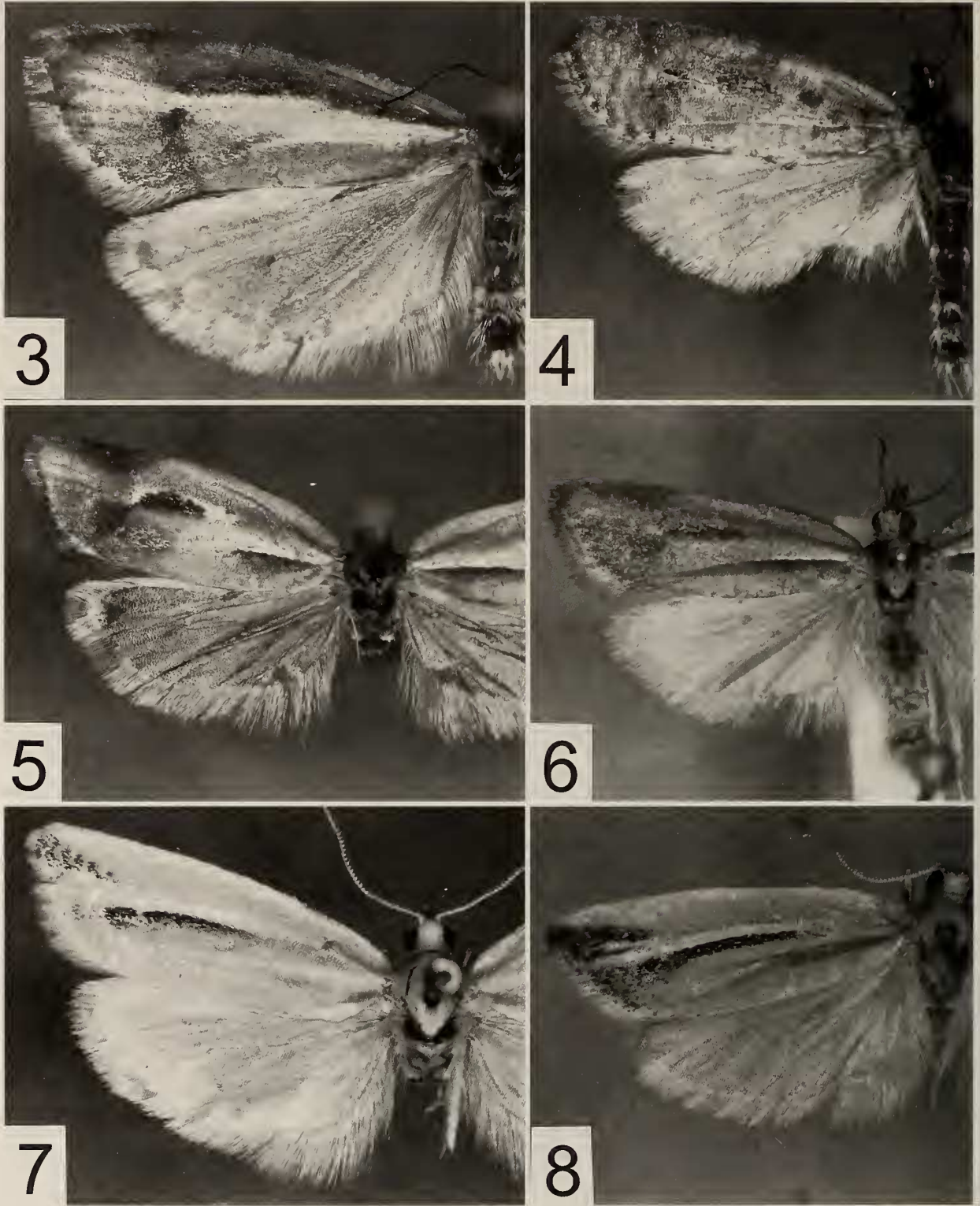

FIGS. 3-8. Adults of *Argyrotaenia*. 3. *A. ponera*; 4. *A. spinacallis*; 5. *A. unda*; 6. *A. octavana*; 7. *A. coconinana*; 8. *A. bialbistriata*.

be distinguished from the latter by a more isolated, narrow, dark rust-brown dash along the costal edge of the discal cell in the distal one-third, although this character is not always obvious. Likewise, male genitalia are not easily separated. In contrast, the female genitalia are separated easily from those of *A. octaviana* by the large, cup-shaped antrum and by the extremely elongate, slender, anteriorly-directed sclerite from the base of the area that bears the capitulum.

Comments. The female genitalia of *A. unda* are similar to those of *A. dichotoma* (Walsingham) (illustrated in Obraztsov 1961:30) in the presence of a large, cup-shaped antrum. However, the adult of *A. dichotoma*, a large, dark-brown moth, with an ill-defined grayish spot near the end of the discal cell and a white hindwing, is superficially quite dissimilar to *A. unda*. It is possible that *A. dichotoma* is a member of the *ponera* group, based on the similarity of the female genitalia to those of *A. unda* and the pale spot at the end of the discal cell, but in the absence of a male (i.e., the species is known only from two females from Guatemala), its assignment to the group would be speculative. While its forewing is narrow like other members of the *ponera* group (i.e., L:W = 2.88), the slightly undulate costa is not consistent with members of this group. It is unusual that Obraztsov (1961) figured the female genitalia of *A. dichotoma* but did not discuss it or formally propose a new combination in the text.

Etymology. The species name is Latin for "wave."

Argyrotaenia octaviana Brown & Cramer, new species

(Figs. 6, 12, 17)

Description. Male. Head: Frons with sparse, smooth scaling below mid eye, copper brown; vertex roughened above, yellowish white. Labial palpus pale red brown mesally, light copper laterally. Antennal scaling pale red brown; scape copper orange, with pale red-brown frosting. Thorax: Copper orange. Forewing (Fig. 6): Length 9.0–10.0 mm (\bar{x} = 9.4; n = 10). Upper side rust to light copper, pale rust brown apically; narrow, pale yellow-brown streak through lower half of discal cell; fine silver-white dot at end of discal cell; thin, silver-white longitudinal line from base to beyond middle of DC. Fringe pale red brown. Under side light gold. Hindwing: Upper side white. Fringe yellowish white. Under side yellowish white. Genitalia: As in Fig. 12 (photograph of JWB slide 1057, Mexico, Mexico; 5 preparations examined). Uncus moderately broad, slightly tapered distally, with truncate tip. Socius, gnathos, and transtilla as in *unda*. Valva short, costa slightly arched dorsally, with a lightly sclerotized subrectangular lobe near base; sacculus moderately long, curved, attenuate distally, ending in a short free pointed tip; base of sacculus with an ill-defined, semicircular lobe. Aedeagus moderately long, not as strongly bent as in *ponera* and *spinacallis*; distal end with 2–4 small spinelike teeth; cornuti 12–15 in a dense fascicle.

Female. FW length 8.0 mm (n = 1). Essentially as described for male, except smaller forewing length and hindwing with dense gray-brown overscaling. Genitalia: As in Fig. 17 (drawn from JWB 1137 slide, Mexico, Veracruz; 1 preparation examined). Papillae anales unmodified, broad. Sterigma moderately heavily sclerotized; ostium bursae moderate in size; antrum a deep, slightly tapered, strongly sclerotized cup. Ductus bursae moderately long, with distinct junction between corpus bursae and ductus bursae. Corpus bursae ovoid; signum an irregular sclerotized patch bearing the capitulum and long spine; posterior- and anterior-directed sclerites absent.

Holotype ♂, Mexico, Puebla, 10 km E Esperanza, 15 August 1987 (J. Brown & J. Powell, UCB).

Paratypes. MEXICO: Puebla: 10 km E Esperanza, 27 ♂, 15 August 1987 (J. Brown & J. Powell, UCB); 10 rd km E Escalante [probably a *lapsus* of Esperanza], 4 ♂, 15 August 1987 (J. Brown & J. Powell, UCB). Veracruz: 22 rd km W Ciudad Mendoza, 2150 m, 12 ♂, 1 ♀, 13 August 1987 (J. Brown & J. Powell, UCB).

Diagnosis. *Argyrotaenia octaviana* is most similar to *A. unda*, from which it can be distinguished by the characters described in the diagnosis of *A. unda* above.

Etymology. The species name refers to the eighth month of the year—all specimens were collected in August.

Argyrotaenia coconinana Brown & Cramer, new species

(Figs. 7, 14, 19)

Description. Male. Head: Frons with sparse, smooth scaling below mid eye, pale red brown; vertex roughened above, pale red brown. Labial palpus light pale red brown mesally, slightly darker pale red brown laterally. Antennal scaling brown; scape pale red brown, with yellowish white scales. Thorax: Pale brown gold. Forewing (Fig. 7): Length 11.0–13.0 mm (\bar{x} = 12.2; n = 10). Upper side pale red brown; a whitish to yellowish-white longitudinal streak extending from near base toward termen through DC; a faint, ill-defined, pale red-brown line immediately above yellowish-white streak, and a well-defined dark copper-brown line immediately below; a well-defined, short line in apical region concolorous with line below yellowish-white streak. Fringe mostly yellowish white, with some pale red brown distally. Under side pale gray. Hindwing: Upper side white, with pale gray overscaling. Fringe concolorous with hindwing. Under side pale gray. Genitalia: As in Fig. 14 (drawn from USNM slide 89386, Arizona, USA; 4 preparations examined). Uncus extremely broad, uniform in width or slightly expanded distally, with truncate tip. Socius small, fused to tegumen. Arms of gnathos moderately long, united distally into pointed tip. Transtilla a simple, sclerotized, narrow band. Valva long, subrectangular, costa weakly arched downward at apex; sacculus moderately long, curved, extending ca. 0.8 distance from base to apex, attenuate distally, conspicuously dentate in distal 0.25. Aedeagus comparatively short, evenly curved near middle; weakly notched distally, with mesal, sclerotized, thornlike process and weak, short, subdistal, accessory lobe; vesica with fascicle of 10–15 long, slender cornuti, curved at base and in distal 0.1.

Female. FW length 11.0–12.0 mm (\bar{x} = 11.4; n = 10). Essentially as described for male, except slightly greater forewing length. Genitalia: As in Fig. 19 (drawn from USNM slide 89387, Arizona, USA; 5 preparations examined). Papillae anales moderately large, flat. Sterigma a slender, strongly sclerotized, rounded band, with a lightly sclerotized disc mesally; ostium bursae slightly recessed; antrum small, in the form of a short, sclerotized, incomplete band at junction of ostium bursae and ductus bursae (=colliculum?). Ductus bursae moderately long, with distinct junction between corpus bursae and ductus bursae. Corpus bursae ovoid; signum with large, subtriangular, sclerotized flanges projecting anterad and posterad from capitulum.

Holotype ♂, USA, Arizona, Coconino Co., Hochderffer Hill, 12.5 mi [20 km] NNW Flagstaff, 8500' [2615 m], 16 July 1964 (J. G. Franclemont, USNM).

Paratypes. USA: ARIZONA: Coconino Co.: Same locality as for holotype, 14 ♂, 16 July 1964, 4 ♂, 1 ♀, 17 July 1964, 1 ♂, 18 July 1964, 1 ♂, 2 ♀, 19 July 1964 (all J. G. Franclemont, USNM, UCB, BMNH); Fort Valley, 7.5 mi [12 km] NW Flagstaff, 7350–7500' [2262–2308 m], 1 ♂, 26 June 1961, 1 ♂, 6 July 1961, 4 ♂, 9 July 1961, 1 ♀, 11 July 1961, 2 ♂, 12 July 1961 (all R. W. Hodges, USNM), 1 ♂, 4 July 1964, 5 ♂, 8 July 1964, 2 ♂, 11 July 1964, 5 ♂, 13 July 1964, 6 ♂, 14 July 1964, 1 ♂, 15 July 1964, 5 ♂, 16 July 1964, 1 ♂, 17 July 1964 (all J. G. Franclemont, USNM); West Fork, 16 mi [25.5 km] SW Flagstaff, 6500' [2000 m], 2 ♂, 4 July 1961, 1 ♂, 8 July 1961, 2 ♂, 19, 13 July 1961, 1 ♀, 19 July 1961 (all R. W. Hodges, USNM), 2 ♂, 3 July 1964 (J. G. Franclemont, USNM); West Fork Oak Creek, 19 road mi [30.4 km] SW Flagstaff, 6500' [2000 m], 1 ♂, 13 July 1995, 2 ♂, 16 July 1995 (J. Powell & F. Sperling, UCB); Walnut Canyon, 6.3 mi [10 km] ESE Flagstaff, 6500' [2000 m], 5 ♂, 5 July 1965 (J. G. Franclemont, USNM), 1 ♂, 14 July 1995, bl. (J. Powell & F. Sperling, UCB). Cochise Co.: Rustler Park, Chiricahua Mtns, 8500' [2615 m], 1 ♀, 3 July 1972, 1 ♂, 12 July 1972, 1 ♀, 14 July 1972, 1 ♀, 27 July 1972, at light (J. Powell, UCB); East Turkey Creek, Chiricahua Mtns., 6400' [1970 m], 1 ♀, 16 June 1966 (J. G. Franclemont, USNM).

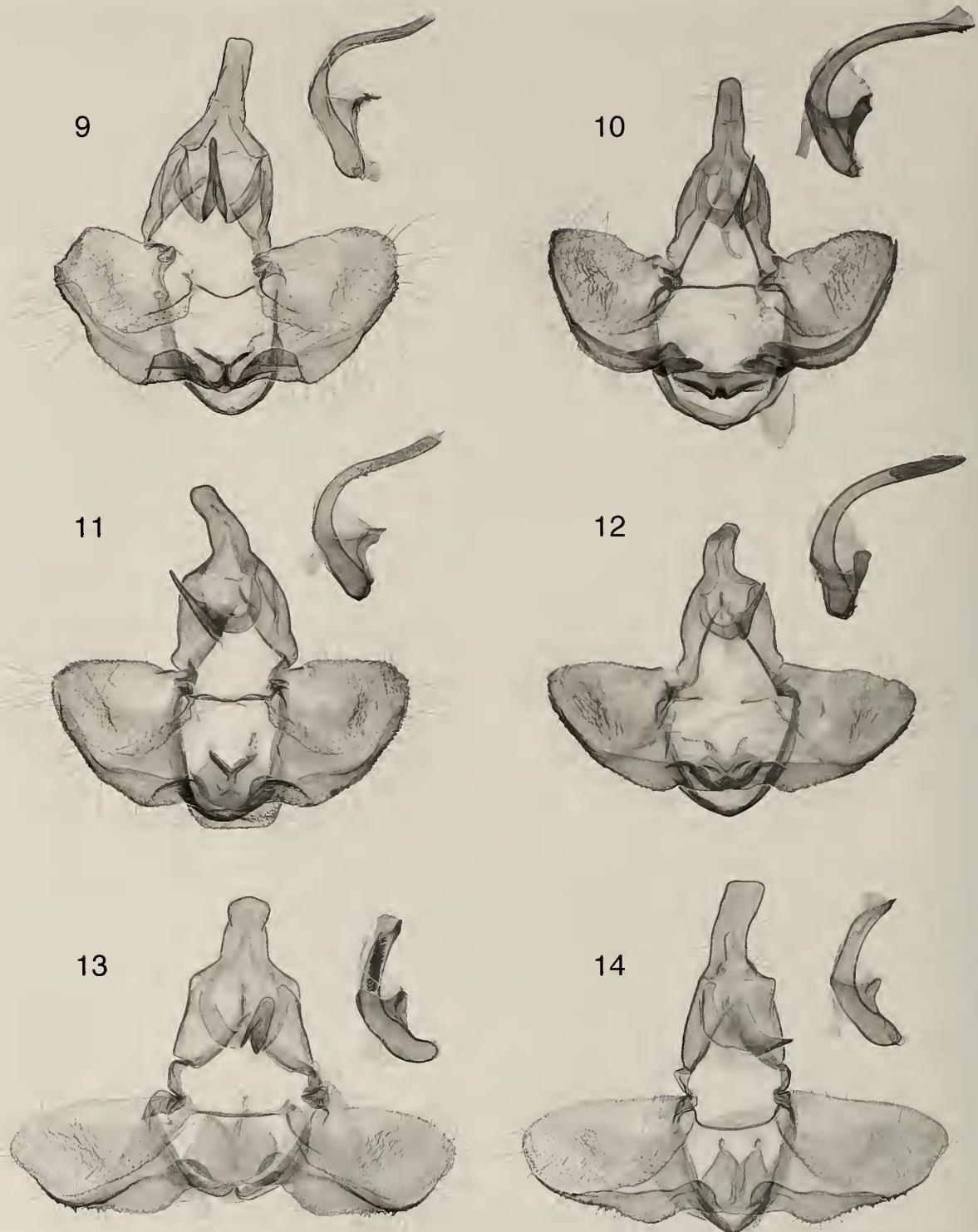

FIGS. 9-14. Male genitalia of *Argyrotaenia*. 9. *A. ponera*; 10. *A. unda*; 11. *A. spinacallis*; 12. *A. octavana*; 13. *A. bialbistrana*; 14. *A. coconinana*.

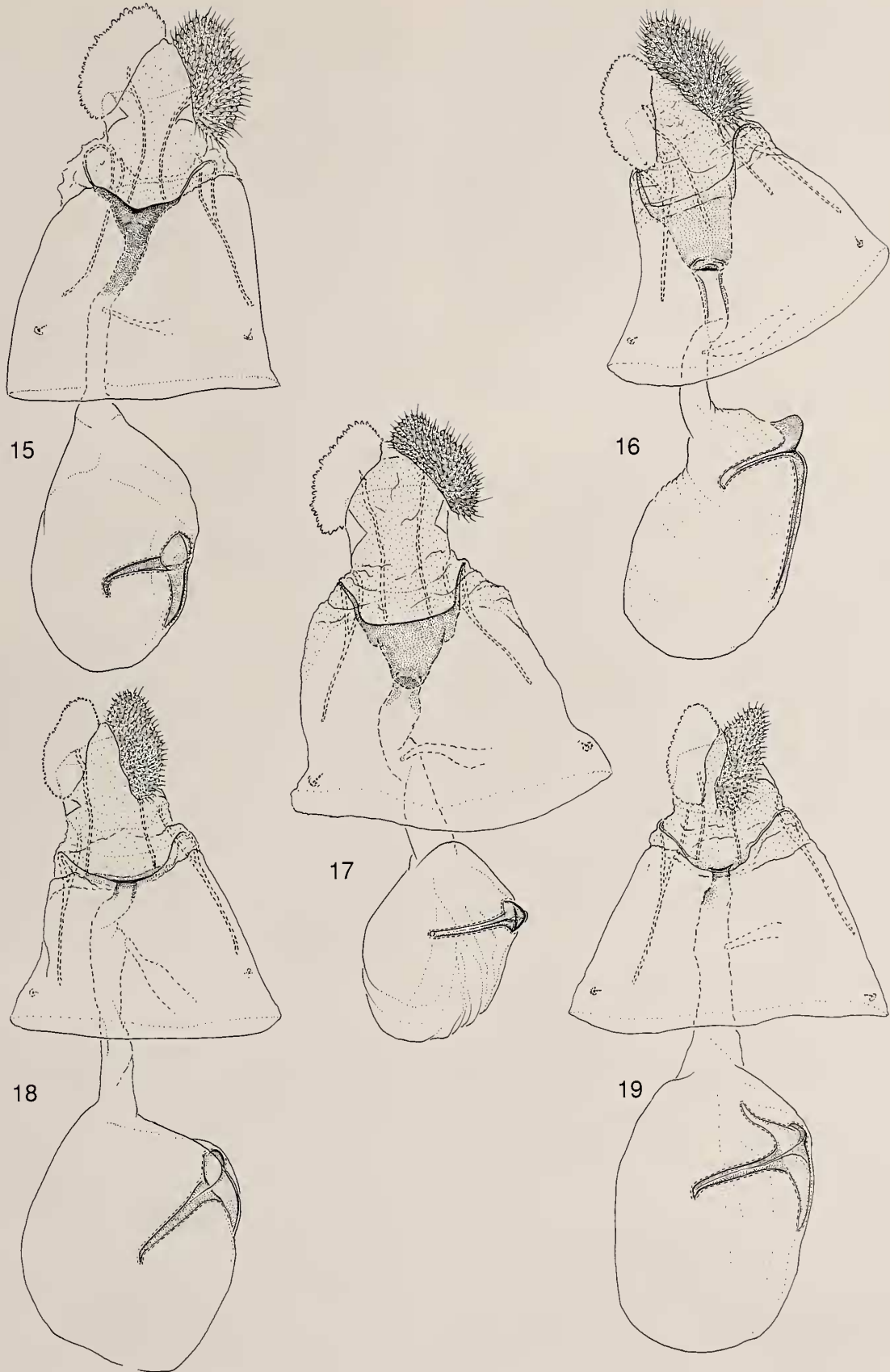

FIGS. 15-19. Female genitalia of *Argyrotaenia*. 15. *A. spinacallis*; 16. *A. unda*; 17. *A. octavana*; 18. *A. bialbistriata*; 19. *A. coconinana*.

Pima Co.: Summerhaven, Mount Lemon, 1 ♀, 21 July 1995, 1 ♀, 9 July 1996 (R. Nagle, RNC). NEW MEXICO: Grant Co.: Cherry Creek Camp, 13 mi [20.8 km] N Silver City, 6900' [2123 m], 1 ♂, 1 ♀, 10 July 1964 (F. P., & M. Rindge, AMNH).

Diagnosis. *Argyrotaenia coconinana* is most similar to *A. bialbistriata*, and their specific distinctness is not entirely certain. The two can be separated by the following: (1) in females of *A. bialbistriata* the longitudinal streak through the discal cell is always silver-white rather than yellowish white or pale cream, and there is a second silver-white longitudinal streak along the lower edge of the discal cell; (2) males of *A. bialbistriata* have considerably darker scaling bordering the lower edge of the pale forewing longitudinal streak and in the apical region; (3) males and females of *A. coconinana* have a greater forewing length; and (4) the signum of *A. coconinana* has a well developed, triangular sclerite projecting posterad from the capitulum that is lacking in *A. bialbistriata*.

Etymology. The species name is derived from the county of Coconino in Arizona.

Argyrotaenia bialbistriata Brown & Cramer, new species

(Figs. 8, 13, 18)

Description. Male. Head: Frons with sparse, smooth scaling below mid eye, pale red brown; vertex roughened above, pale red brown. Labial palpus pale red brown mesally, slightly darker red brown laterally. Antennal scaling brown; scape pale red brown, with yellowish white scales. Thorax: Pale brown-gold. Forewing (Fig. 8): Length 9.8–9.9 mm (\bar{x} = 9.8; n = 2). Upper side pale red brown; a whitish to yellowish-white longitudinal streak extending from near base toward termen through DC; a faint, ill-defined, pale red-brown line immediately above yellowish-white streak, and a well-defined dark copper-brown line immediately below; a well-defined, short line in apical region concolorous with line below yellowish-white streak. Fringe mostly yellowish white, with some pale red brown distally. Under side pale gray. Hindwing: Upper side white, with pale gray overscaling. Fringe concolorous with hindwing. Under side pale gray. Genitalia: As in Fig. 13 (photograph of JWB slide 1091; Durango, Mexico; 2 preparations examined). Uncus extremely broad, uniform in width, with truncate tip. Socius small, fused to tegumen. Arms of gnathos moderately long, united distally into pointed tip. Transtilla a simple, sclerotized, narrow band. Valva long, subrectangular, costa weakly arched downward at apex; sacculus moderately long, curved, extending ca. 0.8 distance from base to apex, attenuate distally, conspicuously dentate in distal 0.25. Aedeagus comparatively short, curved near middle; weakly notched distally, with mesal, sclerotized, thornlike process and weak, short, subdistal, accessory lobe; vesica with fascicle of 10–15 long, slender cornuti, curved at base and in distal 0.1.

Female. FW length 9.5–10.0 mm (\bar{x} = 9.7; n = 3). Essentially as described for male, except forewing maculation much more pale, with a second whitish longitudinal streak along the lower edge of the discal cell. Genitalia: As in Fig. 18 (drawn from JWB slide 1110, Durango, Mexico; 3 preparations examined). Papillae anales moderately large, flat. Sterigma a slender, strongly sclerotized, rounded band, with a lightly sclerotized disc mesally; ostium bursae slightly recessed; antrum small, in the form of a short, sclerotized, incomplete band at junction of ostium bursae and ductus bursae (=colliculum?). Ductus bursae moderately long, with distinct junction between corpus bursae and ductus bursae. Corpus bursae ovoid; signum without sclerotized projection posterad of capitulum.

Holotype ♂, Mexico, Durango, 10 mi (16 km) W El Salto, 9000' [2769 m], 6 June 1964 (J. E. H. Martin, CNC).

Paratypes. MEXICO: Durango: 10 mi (16 km) W El Salto, 9000' [2769 m], 1 ♂, 1 ♀, 6 June 1964 (J. E. H. Martin, CNC).

Additional specimens examined. USA: Arizona: Cochise Co.: Barfoot Park, Chiricahua Mts., 8500' [2615 m], 1 ♀, 14 June 1985 (P. Jump, UCB); Rustler Park, Chiricahua Mtns, 8500' [2615 m], 1 ♀, 3 July 1972, at light (J. Powell, UCB).

Diagnosis. As mentioned in the diagnosis of *A. coconinana*, *A. bialbistriata* is extremely similar to the latter. The most conspicuous character separating the two is the shape of the signum in the female. In *A. bialbistriata* the signum always lacks the large, distally attenuate projection posterad of the capitulum that is always well developed in *A. coconinana*.

Comments. The two female specimens cited above from the Chiricahua Mountains of southeastern Arizona present somewhat of an enigma, suggesting the sympatric and synchronic occurrence of *A. bialbistriata* and *A. coconinana* in the Chiricahua Mountains. There are at least two different interpretations of this information. (1) The two species are sympatric and synchronic in the Chiricahua Mountains of southeastern Arizona, and can be separated by differences in the shape of the signum. This interpretation is supported further by a number of qualitative characters listed in the diagnosis of *A. coconinana*. (2) The two are conspecific, and the apparently distinct shape of the signum and other qualitative differences merely represent infraspecific variation. Although this explanation may be correct, there are no intermediate expressions of the signum shape; i.e., all females throughout the range of *A. coconinana* (except for the two females from the Chiricahua Mountains) are extremely consistent in this character state.

The apparent disjunct occurrence of *A. bialbistriata* in the Chiricahua Mountains of southeastern Arizona and Durango, Mexico, is illustrated by several other Lepidoptera, e.g., *Sparganopseustis martinana* Powell (Tortricidae) (Powell 1986), *Dorithia trigonana* Brown & Obraztsov (Tortricidae) (Brown & Powell 1991), and *Hypaurotis crysalus* (Edwards) (Lycaenidae) (Brown 1989).

Etymology. The species name refers to the two white longitudinal streaks of the forewing of the female.

ACKNOWLEDGMENTS

We thank the following for allowing us to examine material in their care: Kevin Tuck (BMNH), P.T. Dang (CNC), Jerry Powell (UCB), and Ray Nagle, Tucson, Arizona. We thank the following for helpful comments on the manuscript: Jerry Powell, University of California, Berkeley; Steve Nakahara, USDA, Systematic Entomology Laboratory, Beltsville, Maryland; David Smith, USDA, Systematic Entomology Laboratory, National Museum of Natural History, Washington, D.C.; William Miller, University of Minnesota, St. Paul; and Ronald Hodges, Eugene, Oregon. Linda Lawrence, USDA, Systematic Entomology Laboratory, provided the enhanced digital images of the male genitalia; and David Adamski, USDA, Systematic Entomology Laboratory, provided the drawings of the female genitalia. National Science Foundation grant BSR84-11459 to J. Powell funded field work in Mexico in 1987, during which much of the material examined was collected. The taxonomic study was supported in part by a National Science Foundation grant to A. Cramer in the context of the Smithsonian Institution Research Training Program (1998).

LITERATURE CITED

- BROWN, J. W. 1989 (1988). Records of *Hypaurotis crysalus* (Edwards) (Lycaenidae) from western Mexico. *J. Res. Lepid.* 27:135.
- BROWN, J. W. & J. A. POWELL. 1991. Systematics of the *Chrysoxena* group of genera (Lepidoptera: Tortricidae: Euliini). *Univ. Calif. Publ. Entomol.* 111:1–87.
- HORAK, M. 1984. Assessment of taxonomically significant structures in Tortricinae (Lep., Tortricidae). *Mitt. Schweiz. Entomol. Gesel.* 57:3–64.
- LANDRY, B., J. POWELL & F. SPERLING. 1999. Systematics of the *Argyrotaenia franciscana* (Lepidoptera: Tortricidae) species group: evidence from mitochondrial DNA. *Ann. Entomol. Soc. Am.* 92:40–46.
- LIPSCOMB, D. 1994. Cladistic analysis using Hennig86, version 1.5. Documentation for Hennig86 computer program. George Washington University. 122 pp.
- OBRAZTSOV, N. S. 1961. Descriptions of and notes on North and Central American species of *Argyrotaenia*, with descriptions of

- a new genus (Lepidoptera, Tortricidae). *Am. Mus. Novit.* 2048:1-42.
- POWELL, J. A. 1986. Synopsis of the classification of Neotropical Tortricinae, with descriptions of new genera and species (Lepidoptera: Tortricidae). *Pan-Pacif. Entomol.* 62:372-398.
- POWELL, J. A., J. RAZOWSKI & J. W. BROWN. 1995. Tortricidae: Tortricinae, pp. 138-150. *In*: Heppner, J. B. (ed.), *Atlas of Neotropical Lepidoptera, checklist: part 2, Hyblaeoidea-Pyraloidea-Tortricoidea*. Association for Tropical Lepidoptera. Scientific Publishers, Gainesville, Florida.
- RAZOWSKI, J. 1997. Generic composition of the New World Archipini (Lepidoptera, Tortricidae) with description of two new genera and two new species. *Misc. Zool.* 20:125-130.
- WALSINGHAM, LORD T. DE GREY. 1909-1915. *Biologia Centrali-Americana. Insecta, Lepidoptera Heterocera*, Vol. 4. British Museum (Natural History), London. 482 pp. + figs.

Received for publication 15 December 1998; revised and accepted 15 January 2000.